

# ACE

## STAGE ELECTRIC HOIST

ACE 系列舞台电动葫芦



型号/MODEL: ACE-1000 D8 (1Br)

起升速度/LIFTING SPEED: 4M/MIN

起升重量/SAFE WORKING LOAD: 1000KG

产品依照DGUV V54标准符合D8标准

THE PRODUCT COMPLIES WITH DGUV V54 D8 STANDARD

# CONTENTS

## 目录

**产品简介 ..... 3****技术数据 ..... 4**

标准配置 ..... 4

选装配置 ..... 4

线形图 ..... 5

产品爆炸图 ..... 8

**电器数据 ..... 9****PRODUCT INTRODUCTION .... 3****TECHNICAL DATA ..... 4**

STANDARD VERSION ..... 4

OPTIONAL CONFIGURATION ..... 4

LINE GRAPH ..... 5

PRODUCTS EXPLOSION VIEW ..... 8

**ELECTRICAL DATA ..... 9**



产品图片仅供参考，以实物为准。

Images are for reference only. Please refer to the actual product.

Innovative chains side-guiding-out design for quiet and steady operation.

360° swivel hooks made of forged alloy steel. Anti-detaching device is equipped.

Built-in mechanical overload protection clutch to avoid collision and overload damage.

Lifting sprocket is made of special alloy with 5 pockets and double sides bearing. Steady and quiet operation.

The gearbox is formed by die-casting ADC12 aluminum alloy, light and strong with higher strength and better corrosion resistance.

The motor adopts F class, unique heat dissipation function to adapt to high frequency operation, the overall crane protection grade IP66.

The brakes are horizontally opposed brakes, which can be easily upgraded to dual brakes with the addition of brake accessories, and are simple to maintain and replace.

全新的侧出链设计可以保证链条安静而平稳运行。

吊钩采用合金钢锻造，设有防脱钩装置，可360度旋转。

内置式机械超载安全离合器防止超载或是冲顶对葫芦本体及链条带来的损害。

起重链轮由特种合金钢制造，五链窝设计采用双侧轴承，运行平稳安静。

齿轮箱采用ADC12高强度铝合金压铸一体成型，轻巧坚固、强度更高、耐腐蚀性能好。

电机采用F级，独有散热功能适应高频率作业，整体吊机防护等级IP66。

刹车采用水平对置刹车，轻松加配刹车配件即可升级为双刹车，维护更换简单。

## 标准配置

- 设备型号：ACE-1000 D8 (1Br)
- 起重量：1000 KG
- 提升速度 (m/min)：4
- 供电电压：220-440V、3ph、50/60Hz (见图5,P9)
- 供电电缆：1m电源线，带CEE-16A/4芯
- 链条尺寸 EN818-7 (mm)：7.1\*21
- 链条重量 (KG/m)：1.1
- 链条等级：G80
- 链条表面：电泳
- 导链器：带有5个链窝链轮的精密导链器
- 链条行数：1
- 链条袋：1纺织链条袋，可拆卸，≤30米
- 满载噪音 (dB)：≤60
- 制动器：1个直流制动
- 吊钩：1个下(可旋转)
- 悬挂方式：悬挂组件
- 安装方式：自爬或固定
- 手柄：标配
- 防护等级：IP66
- 不含链条重量及吊环、控制线裸机重量(KG)：36.2
- 电机功率 (KW)：1.0
- 电流消耗 (A)：3.7
- 机械等级：FEM 1Am/ISO M4
- 颜色：黑色，色号RAL 9005 哑光
- 离合器：获得专利的摩擦离合器，用于过载保护

## 选装配置

- 链条 选装 G100 (DAT) 链条
- 悬挂方式 选装 吊钩 (见图2,P6)

## STANDARD VERSION

- Model: ACE-1000 D8 (1Br)
- SWL acc.: 1000KG
- Lifting speed (m/min) : 4
- Supply voltage :  
220-440V, 3ph, 50/60Hz (See Figure5, P9)
- Power supply cable : 1m power supply cable, CEE-16A/4 cord
- Chain acc. EN818-7 (mm) : 7.1\*21
- Chain net weight (KG/m) : 1.1
- Grade of chain : G80
- Chain surface : electrophoresis
- Chain guide : precise chain guide with 5-pocket chain wheel
- Chain falls : 1
- Chain bag : 1 textile chain bag, detachable, ≤30 meters
- Full load noise level (db) : ≤60
- Brake: 1 DC brake
- Load hook: 1-fall / turnable
- Suspension: suspension components
- Mounting position: climbing & stationary
- Handles: standard
- Protection level: IP66
- Net weight without chain, hook & suspension, direct control (KG): 36.2
- Motor power (KW) : ca.1.0
- Current consumption (A): ca.3.7
- Mechanism group: FEM 1Am/ISO M4
- Color: black, RAL 9005 matt
- Clutch : patented friction clutch for overload protection

## OPTIONAL

- Chain, optional, G100(DAT) chain
- Suspension method, optional, hook (See Figure2, P6)

# ELECTRIC CHAIN HOIST SIZE

## 电动葫芦尺寸表



图1/Figure 1

链条袋规格/CHAIN BAG SPECIFICATION			
链条长度 CHAIN LENGTH(m)	链条袋尺寸/CHAIN BAG SIZE(mm)		
	a	b	c
10	200	250	180
20	250	250	180
30	350	250	180

注：单位mm/Note:Unit mm

# OPTIONAL HOOK SUSPENSION ASSEMBLY

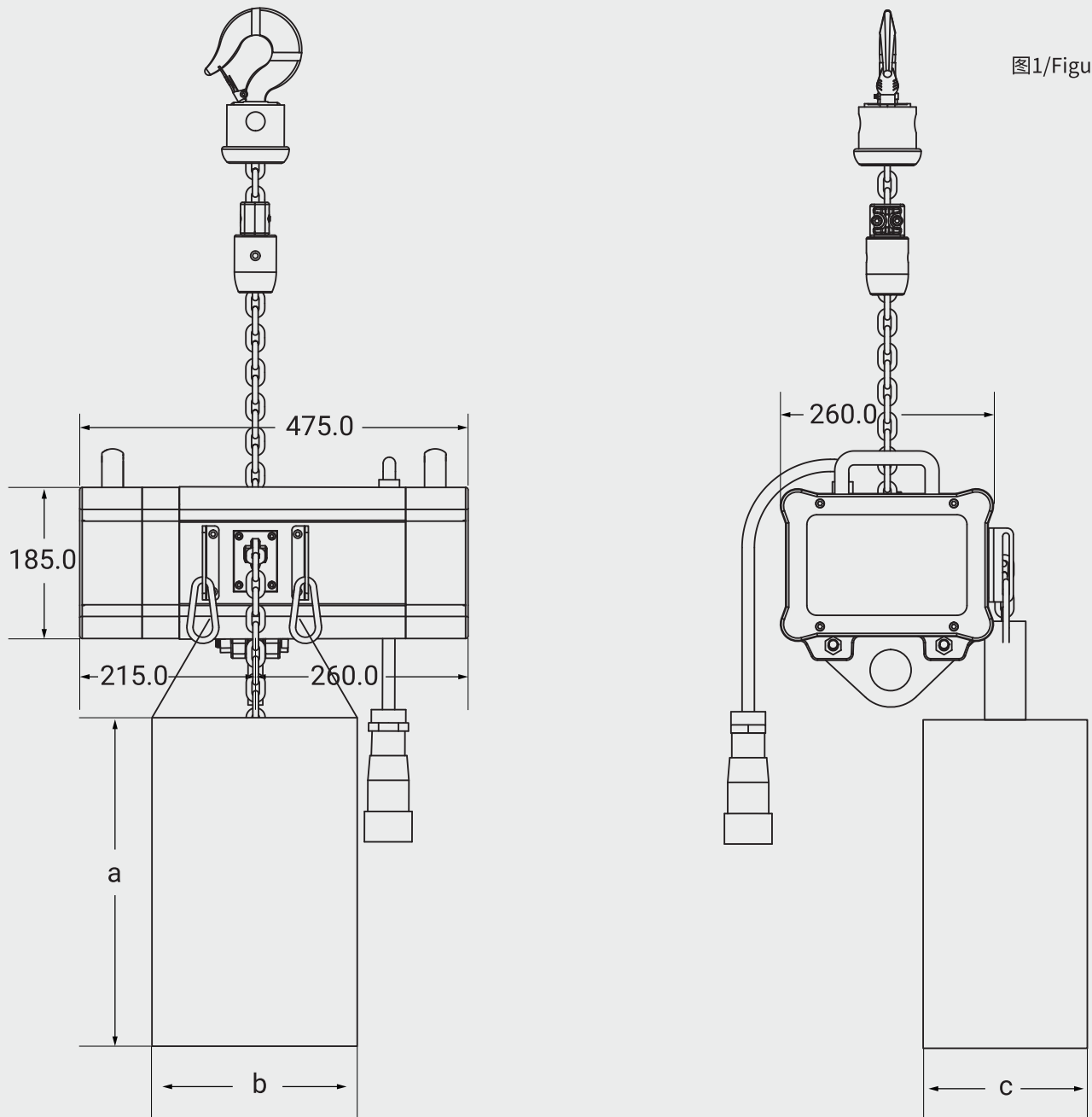
## 吊挂组件

配置1: 360°旋转吊钩悬挂组件

图2/Figure 2

Standard 1: 360° rotating hook suspension assembly

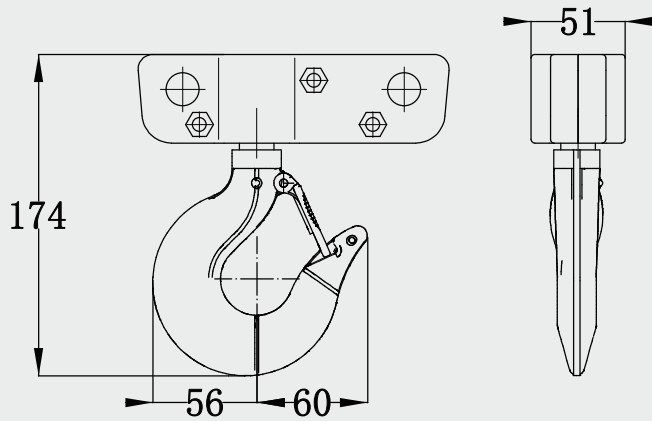

吊钩规格型号 HOOK SPECIFICATION	
J-D-1T	
B2	21
a1	33
b1	7
b2	7
h1	37
h2	35
B1	21
d	40

注: 单位mm/Note: Unit mm

配置2: 吊环组件

图3/Figure 3

Standard 2: Lifting ring assembly

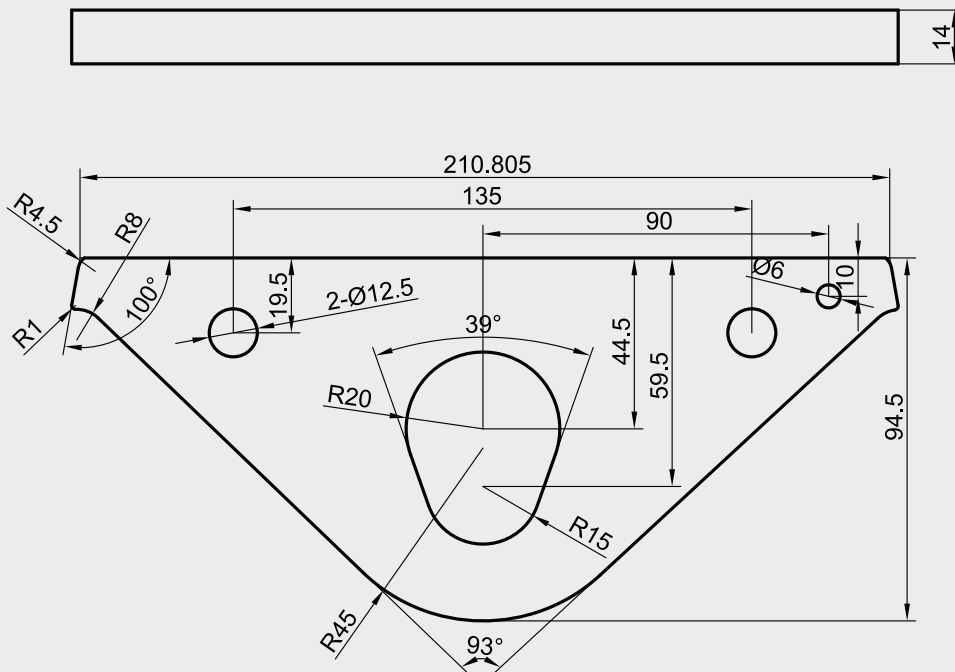

注: 单位mm/Note: Unit mm

# HOOK ASSEMBLY

## 吊钩组件

图4/Figure 4

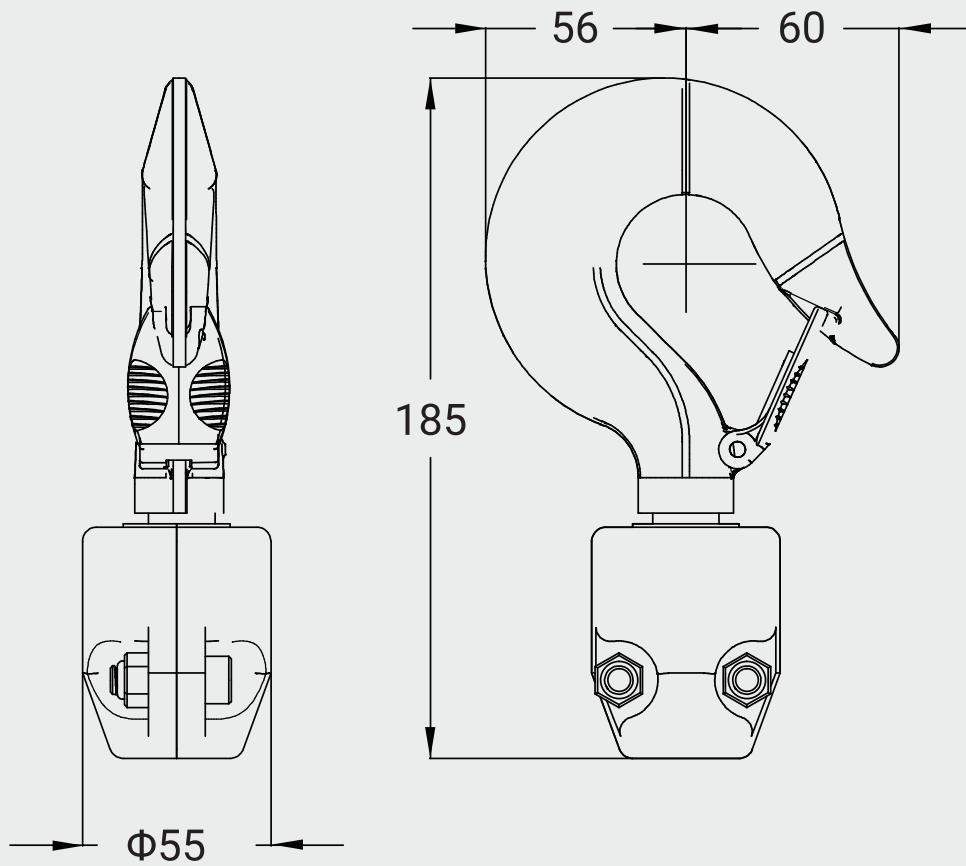

吊钩规格型号 HOOK SPECIFICATION	a1	b1	b2	d	h1	h2	B1	B2
J-D-1T	33	7	7	40	37	35	21	21

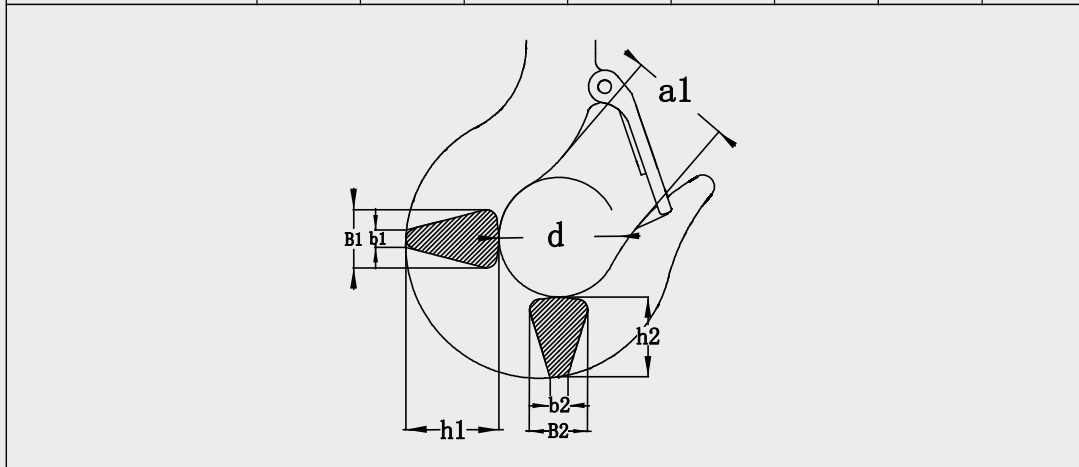

注：单位mm/Note:Unit mm

# PRODUCT STRUCTURE

## 产品结构表

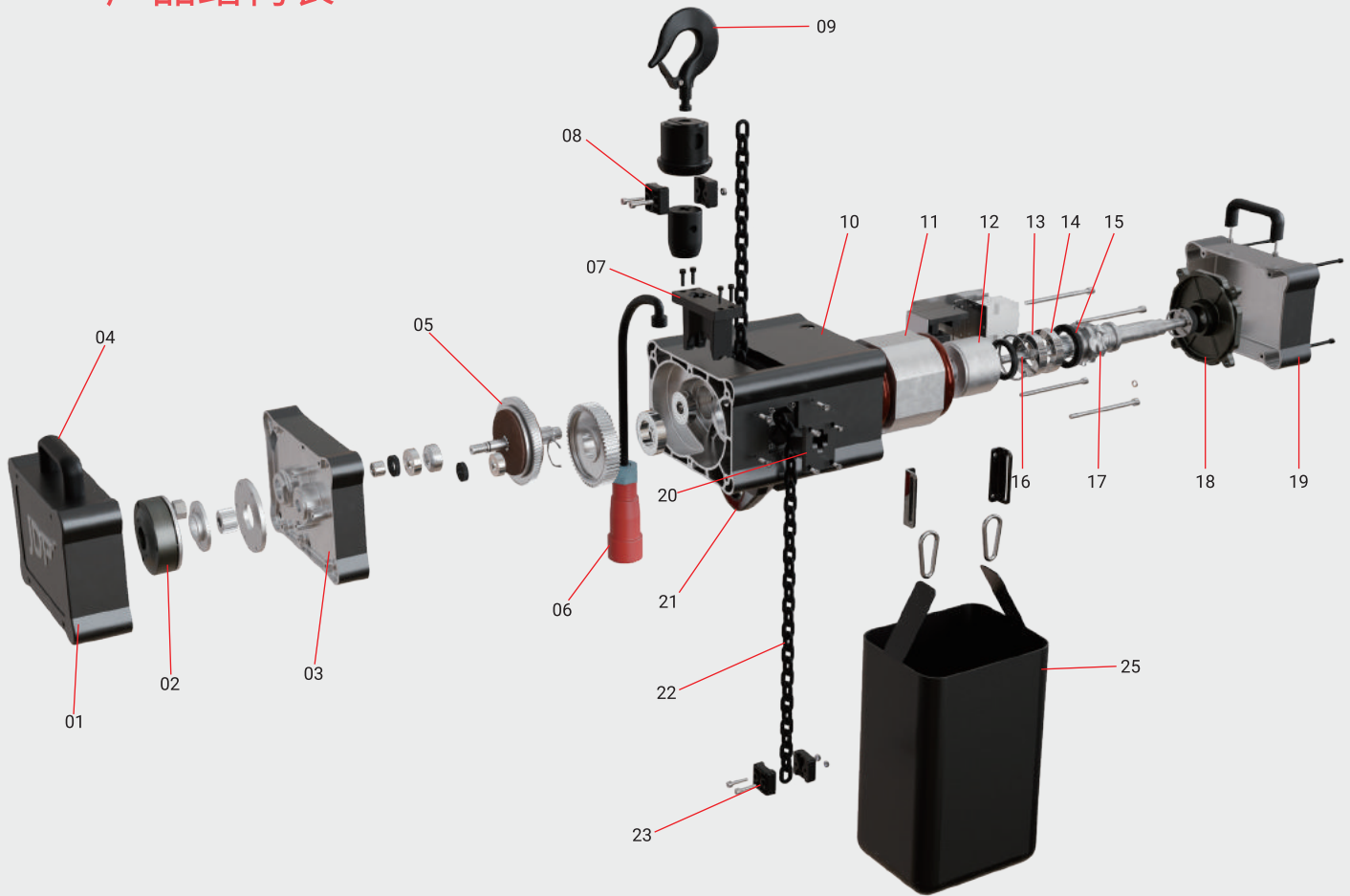

01: 电器端盖	08: 下钩夹板	14: 轴承	20: 侧出链器
02: 电磁刹车	09: 起重钩	15: 轴承固定圈	21: 吊环
03: 齿轮箱盖	10: 齿轮箱	16: 输出轴	22: 链条
04: 提手	11: 电机定子	17: 起重链轮	23: 限位锁块
05: 离合器	12: 转子	18: 制动器底座	24: 储链袋
06: 航空插头	13: 轴承	19: 电器端盖	
07: 导链架			
01: electrical end cover	08: load hook side plate	14: bearing	21: side chain guide
02: DC brake	09: load hook	15: bearing retaining ring	22: suspension ring
03: gearbox end cover	10: gearbox	16: output shaft	22: chain
04: handle	11: stator	17: sprocket	23: limit block
05: clutch	12: rotor	18: brake base	24: chain bag
06: aviation plug	13: bearing	19: electrical end cover	
07: chain guide			

# ELECTRICAL WIRING DIAGRAM

## 电器线路图

高压直控-3Ph+PE/High voltage directly control-3Ph+PE

图5/Figure 5

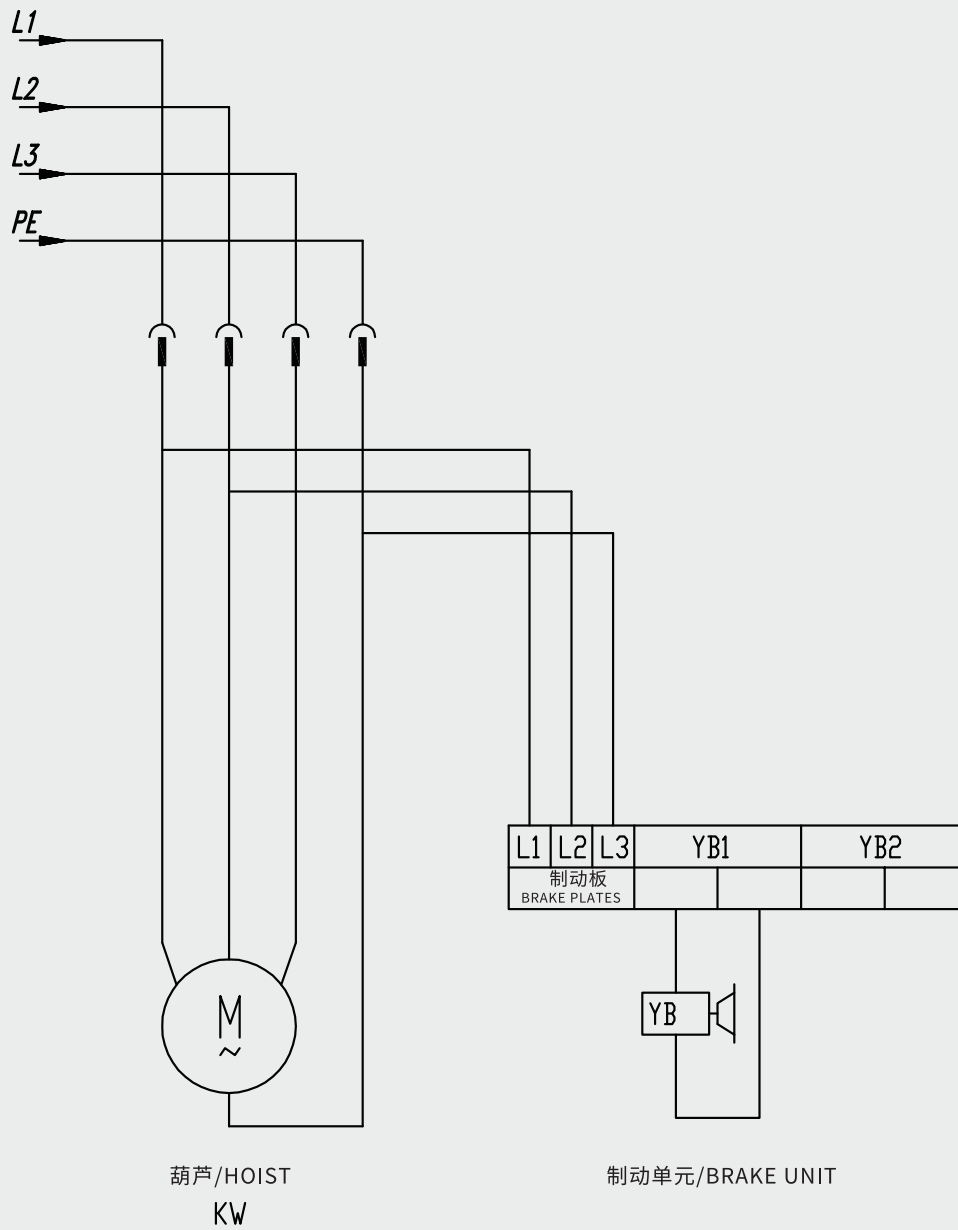

注：不带限位/Note: without limit switch



[www.jdp.top](http://www.jdp.top)

Tel: +86 13315233723 (Wechat number)

WhatsApp: +86 17332256769

[admin@jdp.top](mailto:admin@jdp.top)

Manufacturer: JDP China Drive Systems Co., Ltd